

Архангельск (8182)63-90-72  
Астана (7172)727-132  
Астрахань (8512)99-46-04  
Барнаул (3852)73-04-60  
Белгород (4722)40-23-64  
Брянск (4832)59-03-52  
Владивосток (423)249-28-31  
Волгоград (844)278-03-48  
Вологда (8172)26-41-59  
Воронеж (473)204-51-73  
Екатеринбург (343)384-55-89  
Иваново (4932)77-34-06

Ижевск (3412)26-03-58  
Иркутск (395)279-98-46  
Казань (843)206-01-48  
Калининград (4012)72-03-81  
Калуга (4842)92-23-67  
Кемерово (3842)65-04-62  
Киров (8332)68-02-04  
Краснодар (861)203-40-90  
Красноярск (391)204-63-61  
Курск (4712)77-13-04  
Липецк (4742)52-20-81

Магнитогорск (3519)55-03-13  
Москва (495)268-04-70  
Мурманск (8152)59-64-93  
Набережные Челны (8552)20-53-41  
Нижний Новгород (831)429-08-12  
Новокузнецк (3843)20-46-81  
Новосибирск (383)227-86-73  
Омск (3812)21-46-40  
Орел (4862)44-53-42  
Оренбург (3532)37-68-04  
Пенза (8412)22-31-16

Пермь (342)205-81-47  
Ростов-на-Дону (863)308-18-15  
Рязань (4912)46-61-64  
Самара (846)206-03-16  
Санкт-Петербург (812)309-46-40  
Саратов (845)249-38-78  
Севастополь (8692)22-31-93  
Симферополь (3652)67-13-56  
Смоленск (4812)29-41-54  
Сочи (862)225-72-31  
Ставрополь (8652)20-65-13

Сургут (3462)77-98-35  
Тверь (4822)63-31-35  
Томск (3822)98-41-53  
Тула (4872)74-02-29  
Тюмень (3452)66-21-18  
Ульяновск (8422)24-23-59  
Уфа (347)229-48-12  
Хабаровск (4212)92-98-04  
Челябинск (351)202-03-61  
Череповец (8202)49-02-64  
Ярославль (4852)69-52-93

Киргизия (996)312-96-26-47

Россия (495)268-04-70

Казахстан (772)734-952-31

<https://reliant.nt-rt.ru/> || [rtw@nt-rt.ru](mailto:rtw@nt-rt.ru)

Reliant R906 26G Radar Level Meter Catalog  
File Number: RII202003LM



**R906-26GHz Radar Level Meter**

### **BEST MEASUREMENT PERFORMANCE**

- **Best measurement performance on solid**
- **Optimum level measurement**
- **Reliable level measurement for the most complicate applications**
- **Excellent design to reduce installation cost and eliminate daily maintenance**

### **BEST FIT- FOR- APPLICATION**

- **Wide range up to 20 meters**
- **Wide application of Solid material, Strong dust, easy to crystallize, condensation condition**
- **Wide variety of I/O and expansive communication protocols**

**Copyright © Reliant Instruments Inc. All Rights Reserved**

No part of this publication may be copied or distributed, transmitted, transcribed, stored in a retrieval system, or translated into any human or computer language, in any form or by any means, electronic, mechanical, manual, or otherwise, or disclosed to third parties without the express written permission. The information contained in this manual is subject to change without notice.

## OVERVIEW

This series of radar level meter adopted 26G high frequency radar sensor, the maximum measurement range can reach up to 30 meters. Antenna is optimized further processing, the new fast microprocessors have higher speed and efficiency can be done signal analysis, the instrumentation can be used for reactor, solid silo and very complex measurement environment.

## PRINCIPLE

Radar level transmitter antenna microwave pulse is narrow, the downward transmission antenna. Microwave exposure to the medium surface is reflected back again by the antenna system receives, sends the signal to the electronic circuit automatically converted into level signals (because the microwave propagation speed, electromagnetic wave to reach the target and the reflected back to the receiver this time is almost instantaneous).

- A Range set
- B Low adjustment
- C High
- D Blind area

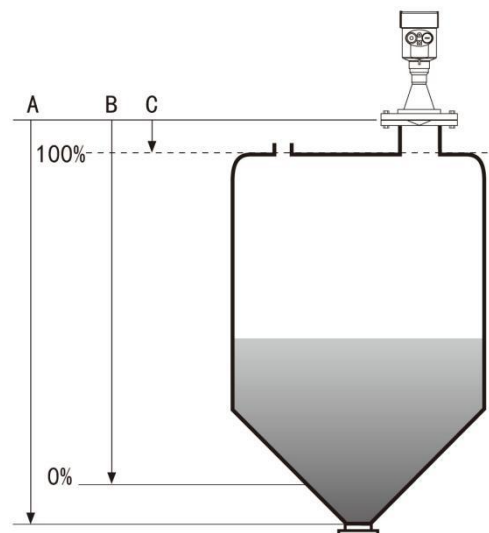

**Datum measurement:** Screw thread bottom or the sealing surface of the flange.

**Note:** Make sure the radar level meter the highest level cannot enter the measuring blind area (Figure D shown below).

## DESIGN & BENEFIT

- ◆ Small antenna size, easy to install; Non-contact radar, no wear, no pollution.
- ◆ Almost no corrosion, bubble effect; almost not affected by water vapor in the atmosphere, the temperature and pressure changes.
- ◆ Serious dust environment on the high level meter work has little effect.
- ◆ A shorter wavelength, the reflection of solid surface inclination is better.
- ◆ Beam angle is small, the energy is concentrated, can enhance the ability of echo and to avoid interference.
- ◆ The measuring range is smaller, for a measurement will yield good results.

- ◆ High signal-to-noise ratio, the level fluctuation state can obtain better performance.
- ◆ High frequency, measurement of solid and low dielectric constant of the best choice.

## APPLICATION

### Industries

- ◆ Chemicals
- ◆ Food & Beverages
- ◆ Machinery
- ◆ Minerals & Mining
- ◆ Oil & Gas
- ◆ Pharmaceuticals
- ◆ Power Plant
- ◆ Pulp & Paper
- ◆ Water
- ◆ Waste Water

## TECHNICAL PARAMETERS

<b>Process Connection</b>	Flange	
<b>Antenna Material</b>	PTFE/ Stainless Steel	
<b>The outer shell</b>		
Seal material of shell and shell	Silicone rubber	
Casing window	Polycarbonate	
Casing window	Polycarbonate	
The ground terminal	Stainless steel	
<b>Power Supply</b>		
<i>2-wire system</i>	Standard type	(16 to 26) V DC
	Intrinsically safe	(21.6 to 26.4) V DC
	Power dissipation	max 22.5mA / 1W
	Allowable ripple	
	$<100\text{Hz}$	$U_{ss}<IV$
	(100 to 100K) Hz	$U_{ss}<10\text{mV}$
<i>Flameproof</i>	(22.8 to 26.4) V DC, 2-wire system (198 to 242)VAC, 4-wire system/110VAC, 4-wire system	
<b>Cable parameters</b>		
Cable entrance / plug	1-M20x1.5 cable entrance, 1- blind plug	
Terminal	Conductor cross section 2.5mm <sup>2</sup>	
<b>Output and Communication</b>		
Output signal	(4 to 20) mA/RS485	
Communication protocol	HART/ Modbus	
Resolution	1.6 $\mu$ A	
Fault signal	Constant current output; 20. 5mA, 22mA ,3.9mA	

Integral time	(0 to 36) s, adjustable
<b>Blind area</b>	the ends of the antenna
<b>Max. distance measurement</b>	20 meters
<b>Accuracy</b>	± 3 mm
<b>Display</b>	LCD, Programmable
<b>Enclosure</b>	IP67
<b>Ex-Grade</b>	Exia II C T6 Ga/ Exd II C T6 Gb
<b>Frequency</b>	26GHz
<b>Communication interface</b>	HART communication protocol
<b>Measurement interval</b>	about 1 second (depend on parameter settings)
<b>Adjust the time</b>	about 1 second (depend on parameter settings)
<b>Display resolution</b>	1 mm
<b>Storage temperature</b>	(-40 to 100) °C
<b>Process Temperature</b>	(-40 to 130)°C / (-40 to 250)°C
<b>Pressure</b>	Max. 4.0MPa
<b>Seismic</b>	Mechanical vibration 10m/s <sup>2</sup> , (10 to 150) Hz

## LINEARITY

Emission angle  
 -  $\varnothing$  76mm  
 Precision

Depending on the size of the antenna  
 12°  
 See chart

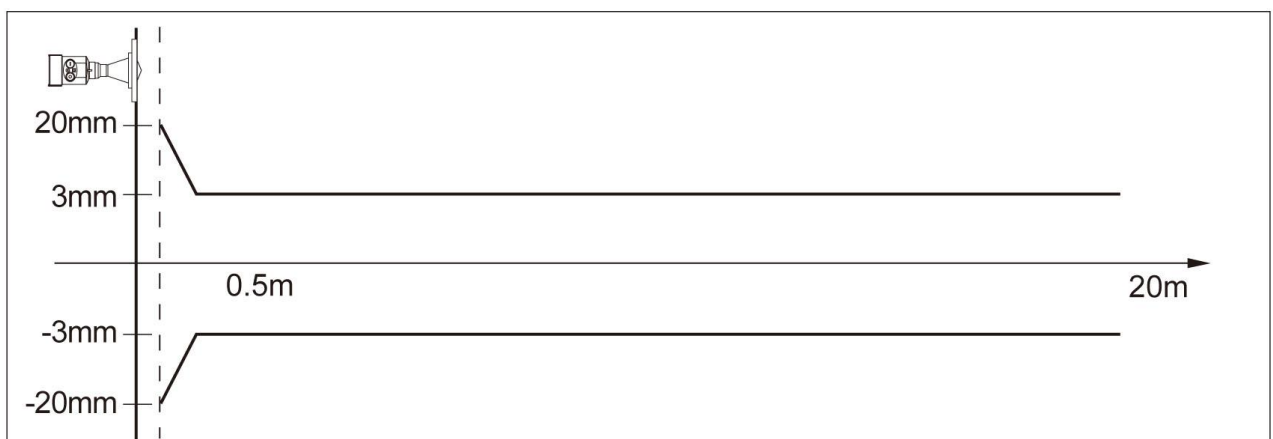

## MODEL SELECTION

- R906-

### Type

- P Standard (Non-explosion-proof)
- I Intrinsically safe (Exia IIC T6 Ga)
- G Flameproof Type (Exd IIC T6 Gb)

### Process Connection / Material

- B Flange DN80 / PTFE
- C Flange DN100 / PTFE
- D Flange DN150 / PTFE
- E Flange DN80 / Stainless Steel 304
- F Flange DN100 / Stainless Steel 304
- G Flange DN150 / Stainless Steel 304
- Y Special Custom Made

### Seal Up / Process Temperature

- V Viton / (-40~130) °C

### Electronic Unit

- 3 (4~20) mA / 24V DC / HART 2-wire system
- 4 (4~20) mA / 220V AC / HART 4-wire system
- 5 RS485 / Modbus / 6~24V / Four wire system

### Outer Covering / Protection Grade

- L Aluminum / Single chamber / IP67
- H Aluminum / Double chamber / IP67
- G Plastic / Single chamber / IP65
- K Stainless steel / Single chamber / IP67

### Cable Line

- M M 20x1.5
- N 1/2" NPT

### Field Display/The Programmer

- A With
- X Without

## INSTALLATION

### 1. The Installation Requirements

- Installation guide:

Be installed in the diameter of the 1/4 or 1/6.  
 Avoid installing in the center of the tank.

Note: ① datum

② The container center or axis of symmetry

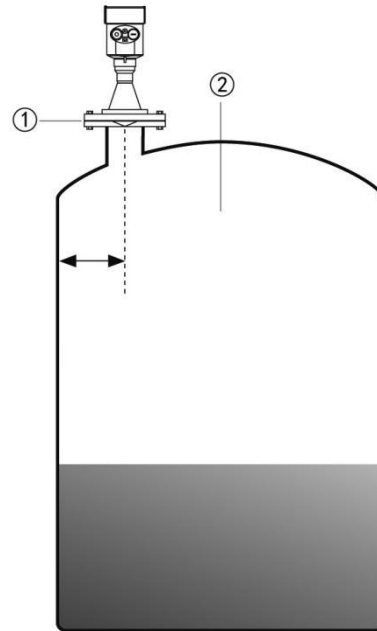

- Take over the installation diagram:

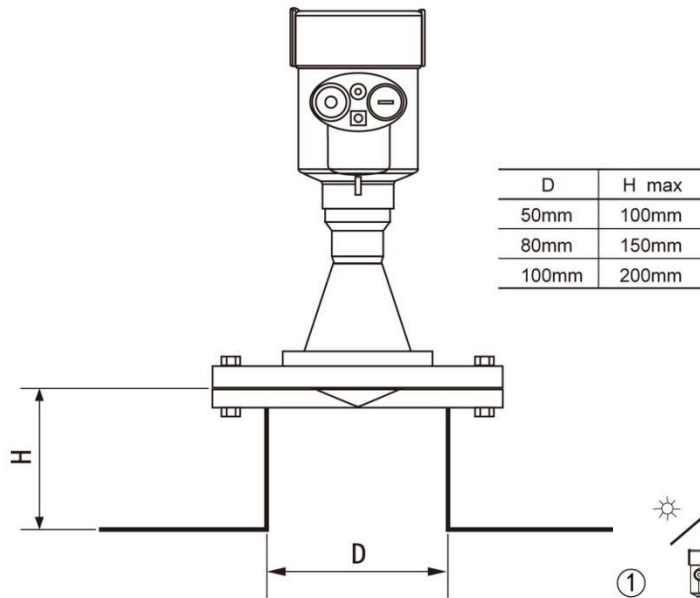

- Typical installation errors:

➤ Conical tank cannot be installed above the feed port.

**Note:** outdoor installation should adopt sunshade.

① Correct rainproof measures

② Error

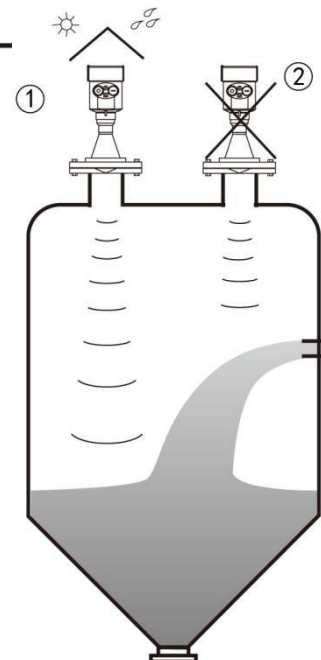

- The instrument cannot be installed in the arched or domed roof intermediate. In addition to produce indirect echo is also affected by the echoes. Multiple echo can be larger than the real value of signal echo, because through the top can concentrate multiple echo. So cannot be installed in a central location.

- ① Correct
- ② Error

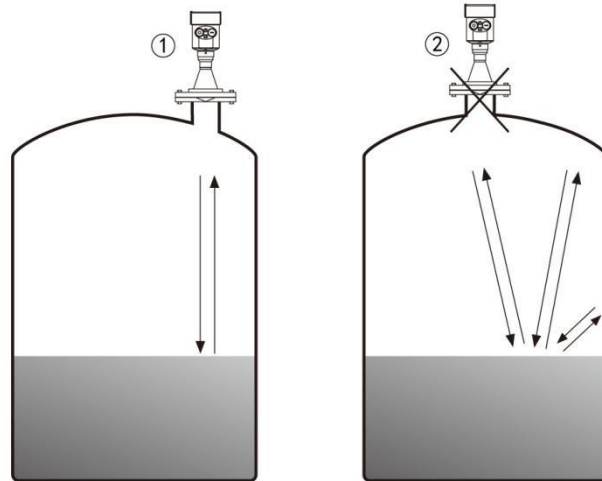

- There are obstacles affecting measurement needed reflection plate.

- ① Correct
- ② Error

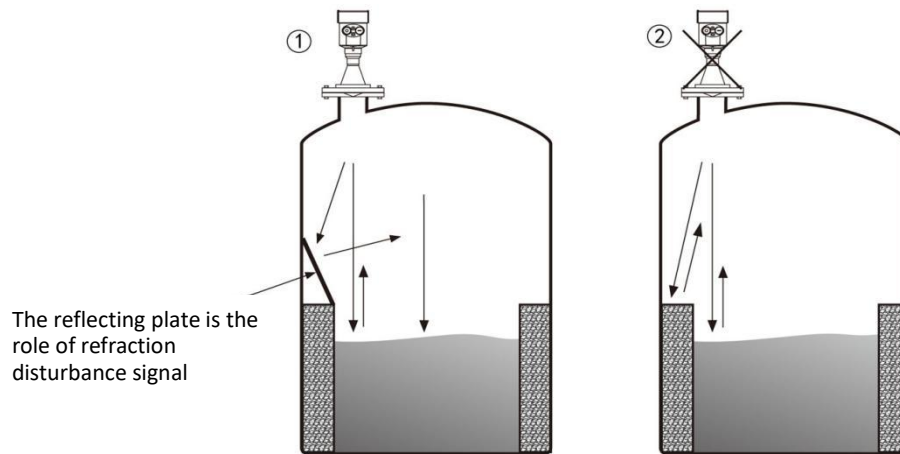

## ELECTRICAL CONNECTION

### ● The power supply voltage:

(4to20)mA/HART (2-wire system)	The power supply and the output current signal sharing a two core shield cable. The supply voltage range see technical data. For intrinsically safe type must be a safety barrier between the power supply and the instrument.
(4to20)mA/HART (4-wire system)	Separate power supply and the current signal, respectively using a two-core shielded cable. The supply voltage range see technical data.
RS485 / Modbus	Power supply and Modbus signal line separated respectively using a two-core shielded cable, the power supply voltage range see technical data.



● **Connection mode:**

- 24V two wire wiring diagram as right:

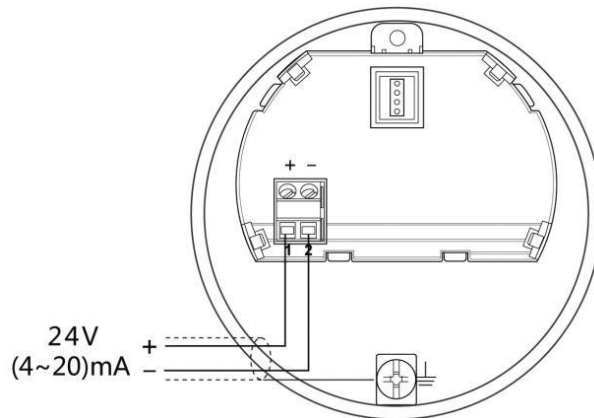

- 6 to 24V RS485/Modbus wiring diagram as right:

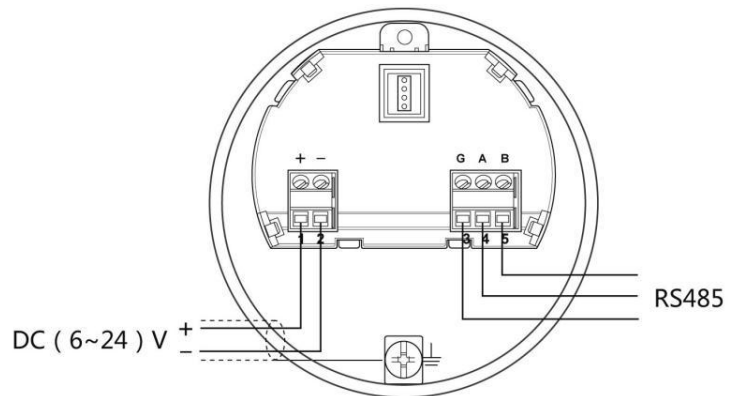

● **Explosion Proof Connection**

The intrinsic safety version sensors (Exia IIc T6) use Alu-die casting housing and filling Silicone rubber sealants internal structure aimed to prevent sparks resulted from circuit failure from leaking out. It is applicable for the continuous level measurement of flammable medium under Exia IIc T6.

A safety barrier FBS-2 must be used together with the intrinsic safety instrument. It is an associated device to this product for the power supply of this product. The main specification is intrinsic safety: Exia IIC, voltage of power supply: 24VDC  $\pm$  5%, short-circuit current: 135mA, operating current: 4 to 20mA.

All cables must be shielded. The max length is 500m for the cable from the barrier to the sensor. Stray capacitor  $\leq 0.1 \mu F/Km$ , stray inductance 1mH/Km. Instrument must be connected to the ground potential. Any unapproved associated device is not allowed to be used.

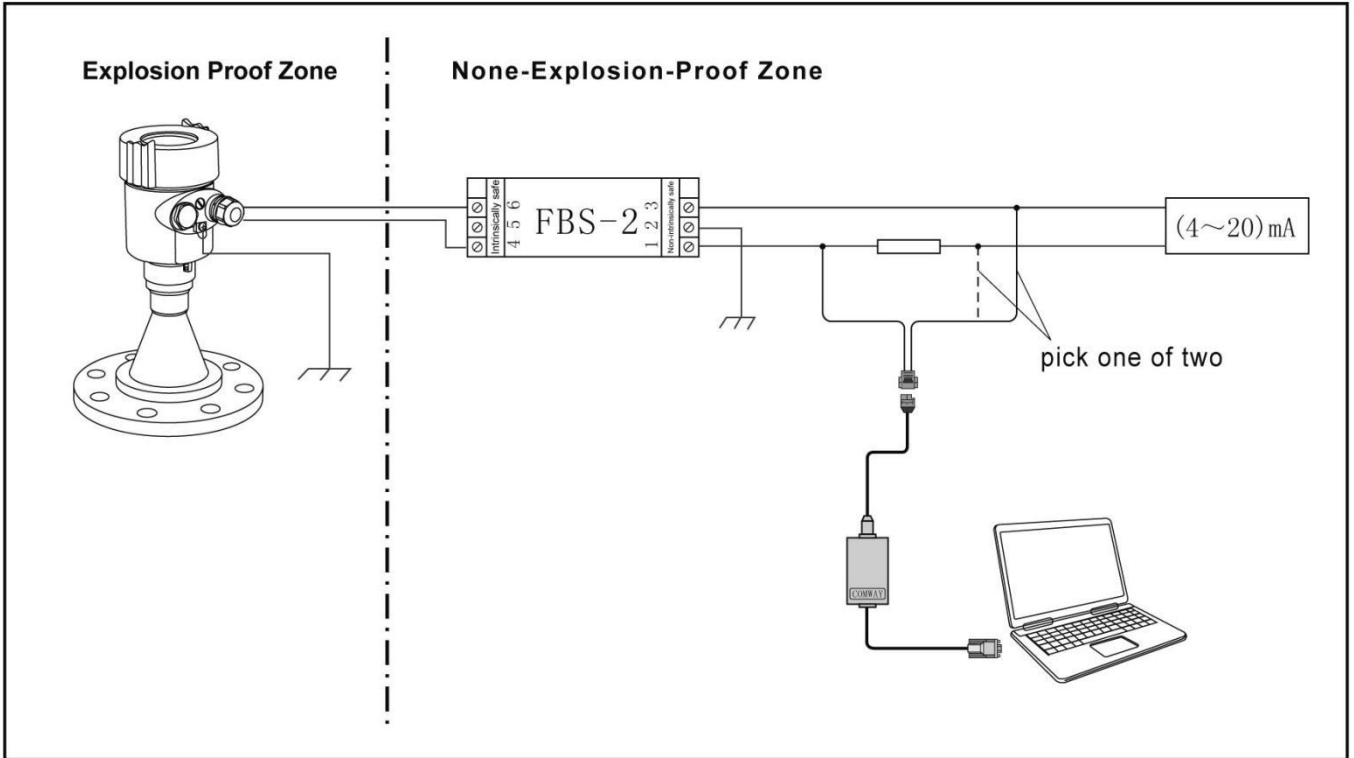

Adjustment with Software

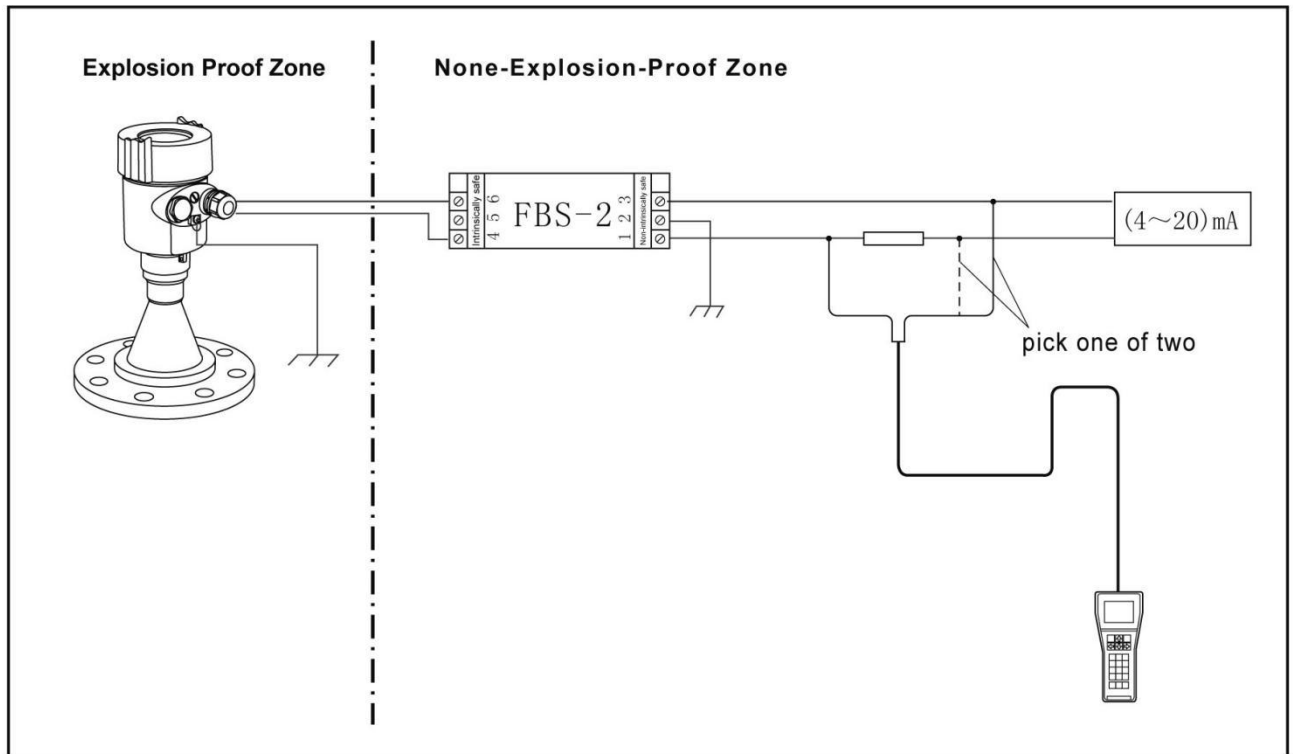

Adjustment with HART Handheld Programmer

- **Safety instructions:**

- Please observe the local electrical code requirements!
- Please comply with local requirements for personnel health and safety regulations.  
All electrical components of instrument operation must be completed by the formal training of professionals.
- Please check the instrument nameplate to provide product specifications meet your requirements.  
Please make sure that the power supply voltage and instrument nameplate on the requirements.

- **Enclosure grade:**

This instrument meets the enclosure class IP66/67 requirements, please ensure the waterproof cable sealing head. The following diagram:

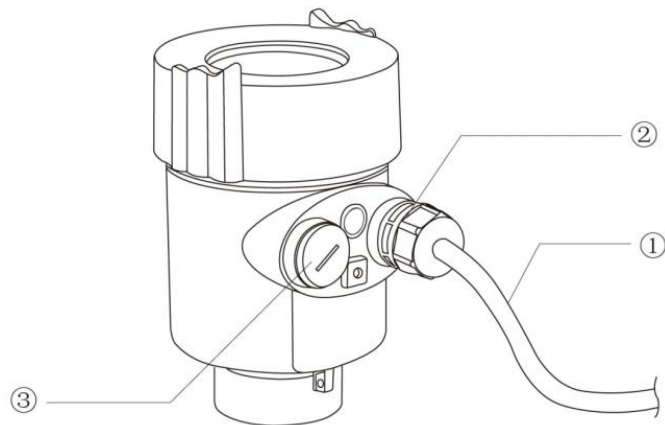

**How to install to meet the requirements of IP67:**

Please make sure that the sealing head is not damaged.

Please make sure that the cable is not damaged.

Please make sure that the cable for use with electrical connection specification.

Cable into the electrical interface before its curved downward, ensure that the water will not flow into the shell, see the ①

Tighten the cable seal head, see the ②

Please electrical interface will not use blind plug tight, see the ③

## INSTRUMENT COMMISSIONING

- **There are three kinds of debugging method:**

- 1) Display / Keyboard
- 2) Host debugging
- 3) HART handheld programmer

● **Display / Keyboard:**

Please debug the instrumentation by four buttons on the display screen. There are three debug menu languages optional. After debugging is generally used only for display, through the glass window can read measured value very clearly.

Display / Keyboard

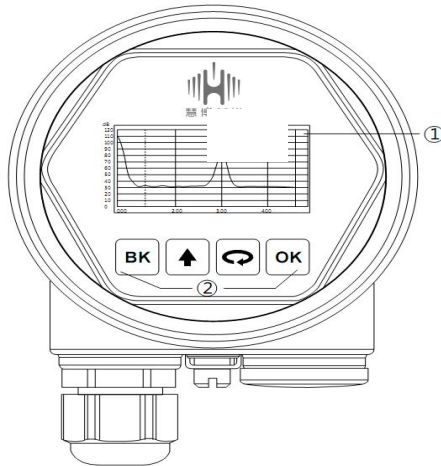

① Liquid crystal display(LCD)

② The key

● **PC debugging:**

Connected to PC by HART

- ① RS232 interface or USB interface
- ② Radar level meter
- ③ HART adapter
- ④ 250 Ω resistor

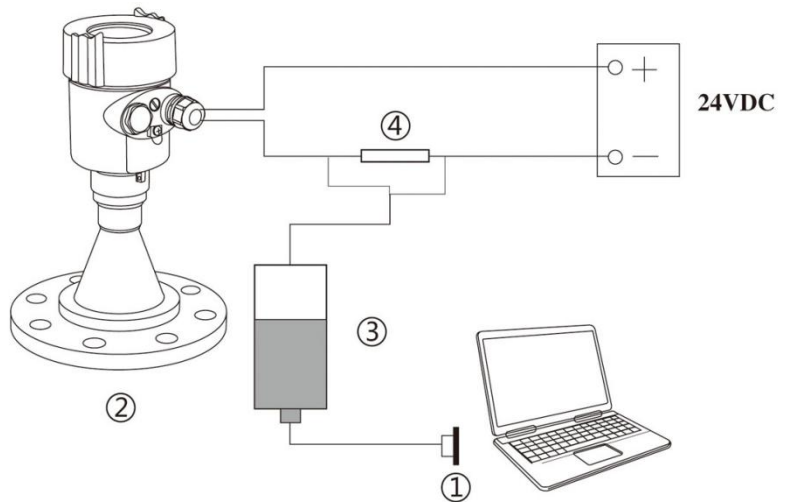

● **HART handheld programmer:**

- ① HART handheld programmer
- ② Radar level meter
- ③ 250 Ω resistor

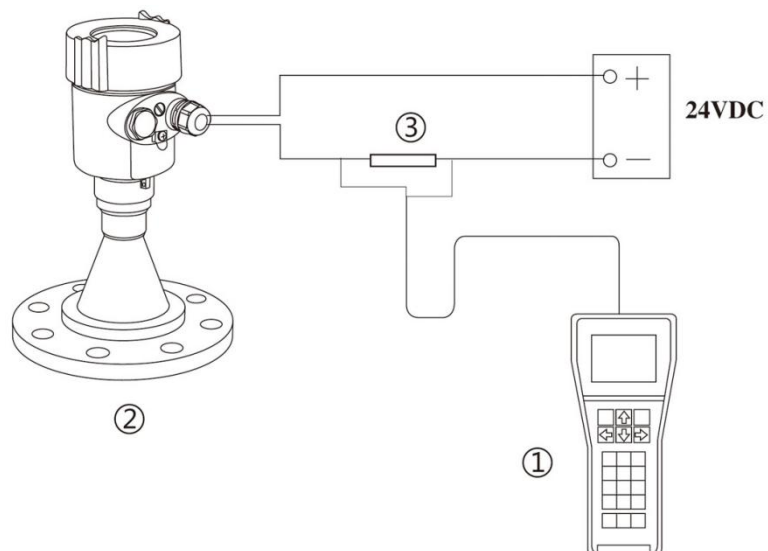

## 2. Structure Size (Unit: mm)

- The outer shell:

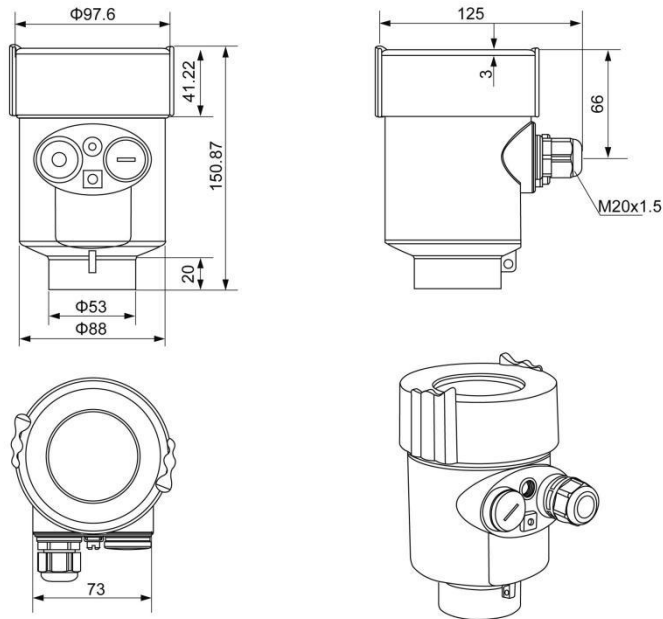

- Appearance size:

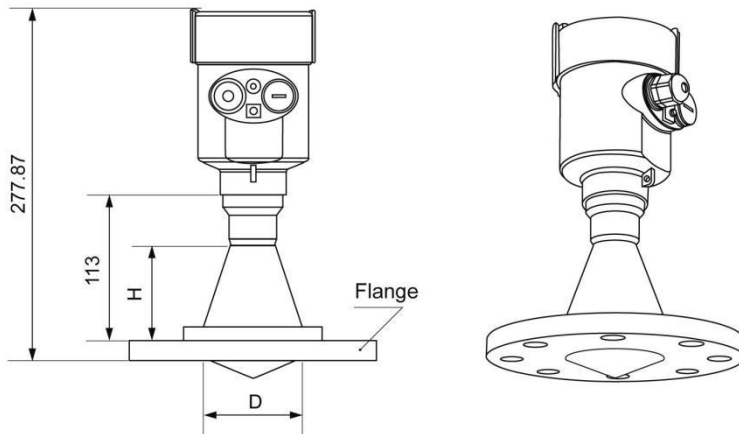

Flange	Trumpet diameter D	Trumpet height H
DN80	$\Phi 76$	80
DN100	$\Phi 76$	80

- Flange type:

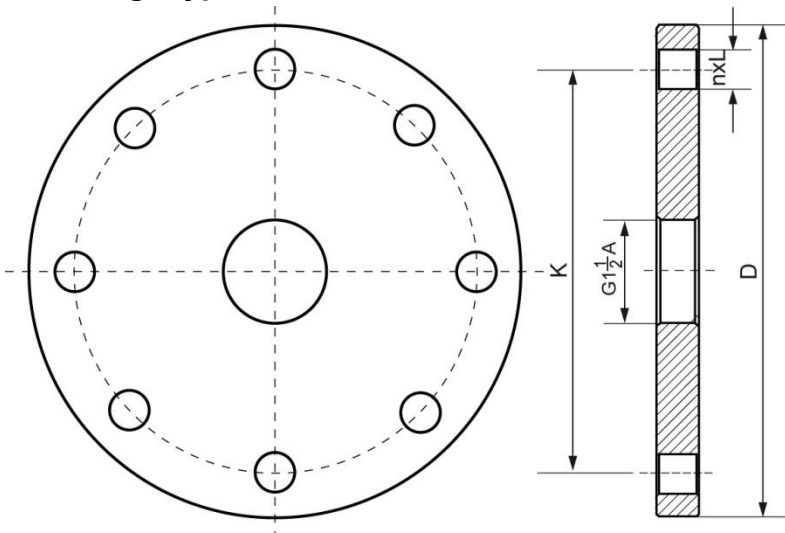

Size	D	K	n	L
DN80	$\Phi 200$	$\Phi 160$	8	18
DN100	$\Phi 220$	$\Phi 180$	8	18

Архангельск (8182)63-90-72  
Астана (7172)727-132  
Астрахань (8512)99-46-04  
Барнаул (3852)73-04-60  
Белгород (4722)40-23-64  
Брянск (4832)59-03-52  
Владивосток (423)249-28-31  
Волгоград (844)278-03-48  
Вологда (8172)26-41-59  
Воронеж (473)204-51-73  
Екатеринбург (343)384-55-89  
Иваново (4932)77-34-06

Ижевск (3412)26-03-58  
Иркутск (395)279-98-46  
Казань (843)206-01-48  
Калининград (4012)72-03-81  
Калуга (4842)92-23-67  
Кемерово (3842)65-04-62  
Киров (8332)68-02-04  
Краснодар (861)203-40-90  
Красноярск (391)204-63-61  
Курск (4712)77-13-04  
Липецк (4742)52-20-81

Магнитогорск (3519)55-03-13  
Москва (495)268-04-70  
Мурманск (8152)59-64-93  
Набережные Челны (8552)20-53-41  
Нижний Новгород (831)429-08-12  
Новокузнецк (3843)20-46-81  
Новосибирск (383)227-86-73  
Омск (3812)21-46-40  
Орел (4862)44-53-42  
Оренбург (3532)37-68-04  
Пенза (8412)22-31-16

Пермь (342)205-81-47  
Ростов-на-Дону (863)308-18-15  
Рязань (4912)46-61-64  
Самара (846)206-03-16  
Санкт-Петербург (812)309-46-40  
Саратов (845)249-38-78  
Севастополь (8692)22-31-93  
Симферополь (3652)67-13-56  
Смоленск (4812)29-41-54  
Сочи (862)225-72-31  
Ставрополь (8652)20-65-13

Сургут (3462)77-98-35  
Тверь (4822)63-31-35  
Томск (3822)98-41-53  
Тула (4872)74-02-29  
Тюмень (3452)66-21-18  
Ульяновск (8422)24-23-59  
Уфа (347)229-48-12  
Хабаровск (4212)92-98-04  
Челябинск (351)202-03-61  
Череповец (8202)49-02-64  
Ярославль (4852)69-52-93

Киргизия (996)312-96-26-47

Россия (495)268-04-70

Казахстан (772)734-952-31

<https://reliant.nt-rt.ru/> || [rtw@nt-rt.ru](mailto:rtw@nt-rt.ru)